

# Open-Source Syringe Pump

(developed by Andrey Samokhin in 2018)

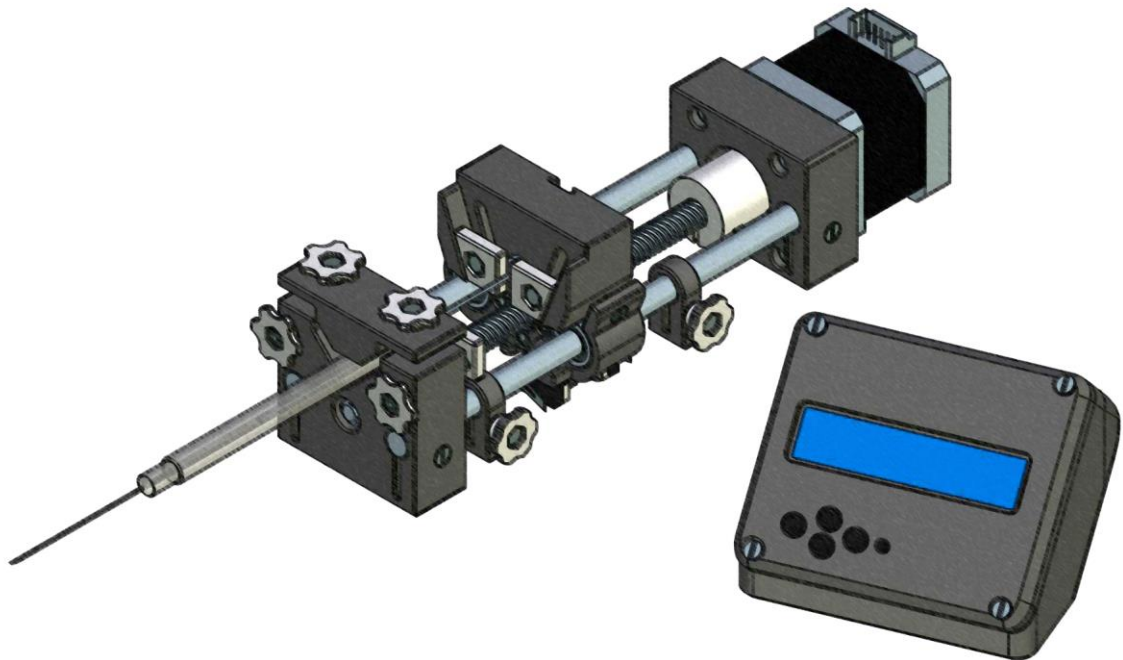

## Assembly Instructions

(Version 1.0a)

STL-files and "firmware" are available at [http://www.mass-spec.ru/projects/diy/syringe\\_pump/eng/](http://www.mass-spec.ru/projects/diy/syringe_pump/eng/)

Project files are distributed under CC BY-SA 4.0 license



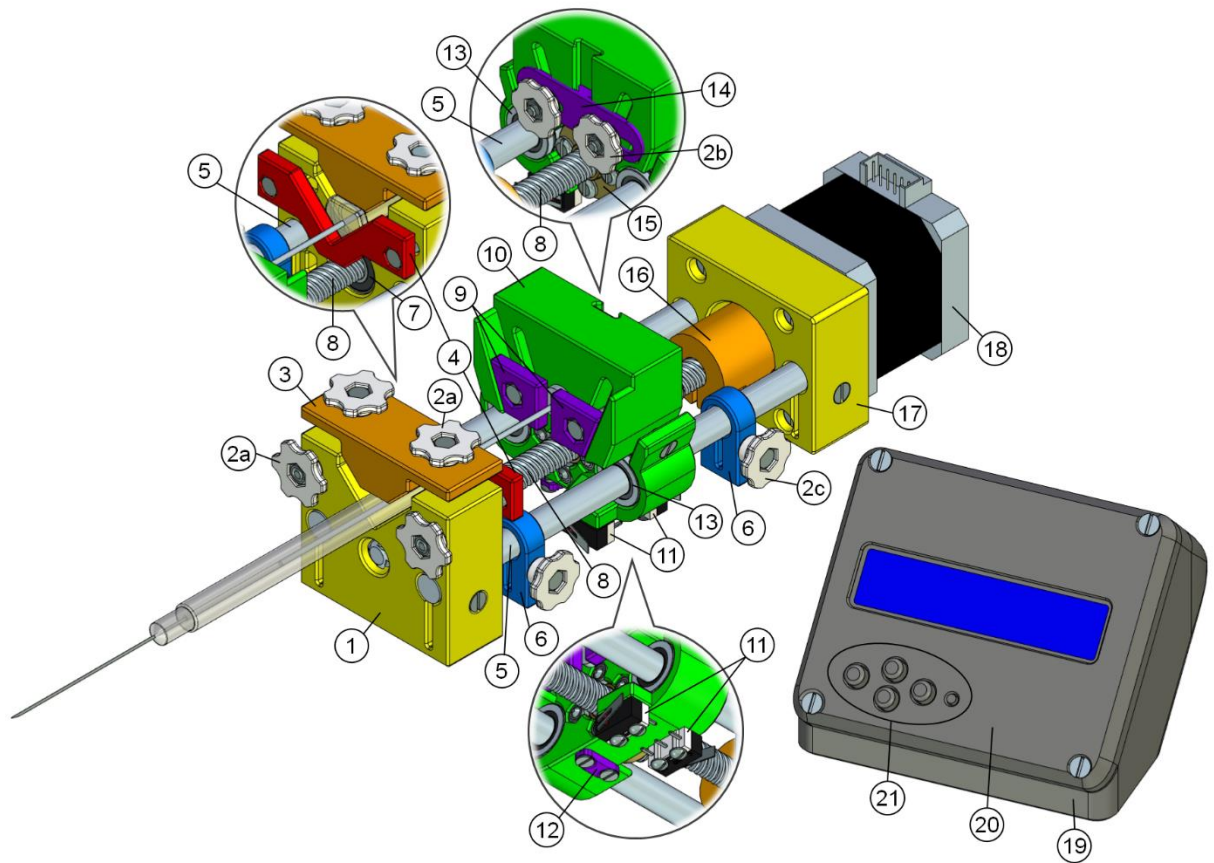

Fig. 1. General view.

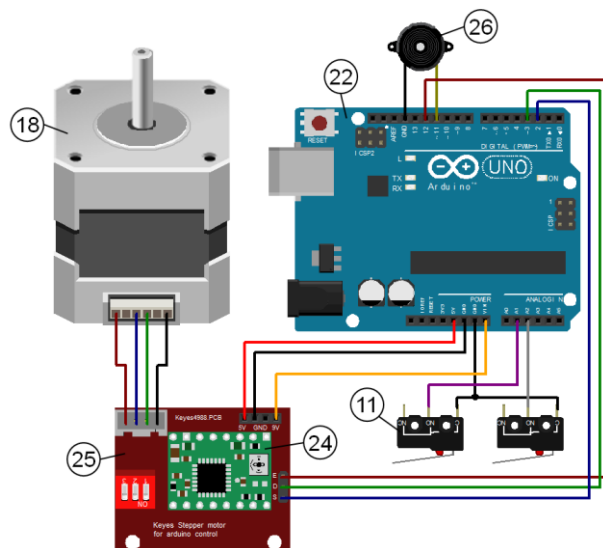

Fig. 2. Electrical circuit.

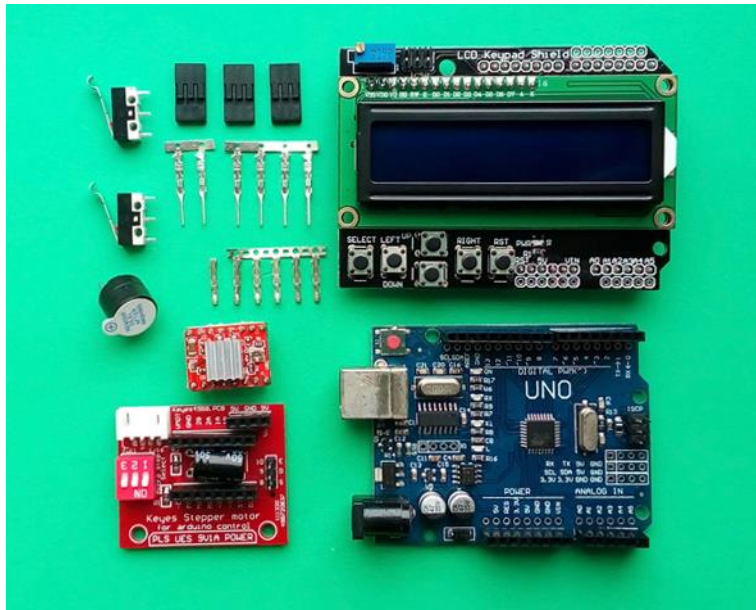

Fig. 3. Electronic components.



Fig. 4. Plastic parts made on 3D printer.



Fig. 5. Plastic case made on 3D printer.



Fig. 6. Guide rods, lead screw with nut, metal rigid coupling, bearings, stepper motor, screws and nuts.

Table 1. Part list.

| <b>PART #</b> | <b>PART NAME</b>             | <b>QTY</b> |
|---------------|------------------------------|------------|
| 1             | Front Support                | 1          |
| 2a            | Hand Knob (9 mm)             | 4          |
| 2b            | Hand Knob (8 mm)             | 2          |
| 2c            | Hand Knob (7 mm)             | 2          |
| 3             | Top Syringe Holder           | 1          |
| 4             | Side Syringe Holder          | 1          |
| 5             | Guide Rod (D=8 mm)           | 2          |
| 6             | Limit Stop                   | 2          |
| 7             | Bearing 688ZZ                | 1          |
| 8             | Lead Screw (T8)              | 1          |
| 9             | Plunger Holders              | 1          |
| 10            | Carriage                     | 1          |
| 11            | Endstop Switch               | 2          |
| 12            | Wire Holder                  | 1          |
| 13            | Linear Bearing (LM8SUU)      | 2          |
| 14            | Slider                       | 1          |
| 15            | Lead Screw Nut (T8)          | 1          |
| 16            | Coupling                     | 1          |
| 17            | Back Support                 | 1          |
| 18            | Stepper Motor (NEMA 17)      | 1          |
| 19            | Case (Base)                  | 1          |
| 20            | Case (Cover)                 | 1          |
| 21            | Buttons                      | 1          |
| 22            | Arduino UNO                  | 1          |
| 23            | LCD Keypad Shield            | 1          |
| 24            | Stepper Motor Driver (A4988) | 1          |
| 25            | Control Shield for A4988     | 1          |
| 26            | Active Buzzer (D=12 mm)      | 1          |
| 27            | Nut M3                       | 20         |
| 28            | Countersunk Screw M3x12      | 4          |
| 29            | Countersunk Screw M3x14      | 4          |
| 30            | Countersunk Screw M3x20      | 4          |
| 31            | Pan Head Screw M3x16         | 4          |
| 32            | Bolt M3x20                   | 2          |
| 33            | Bolt M3x25                   | 2          |
| 34            | Bolt M3x35                   | 4          |
| 35            | Self-tapping Screw 2x8       | 6          |
| 36            | Self-tapping Screw 2x10      | 8          |
| 37            | Dupont Connector (Female)    | 6          |
| 38            | Dupont Connector (Male)      | 6          |
| 39            | Dupont Housing (3P)          | 3          |
| 40            | Connector Wires              | –          |
| 41            | Power Supply (12 V, 2 A)     | 1          |

### Step 1.1 (assemble according to the drawing)

| PART # | PART NAME               | QTY |
|--------|-------------------------|-----|
| 8      | Lead Screw (T8)         | 1   |
| 16     | Coupling                | 1   |
| 18     | Stepper Motor (NEMA 17) | 1   |
| 27     | Nut M3                  | 2   |
| 28     | Countersunk Screw M3x12 | 2   |

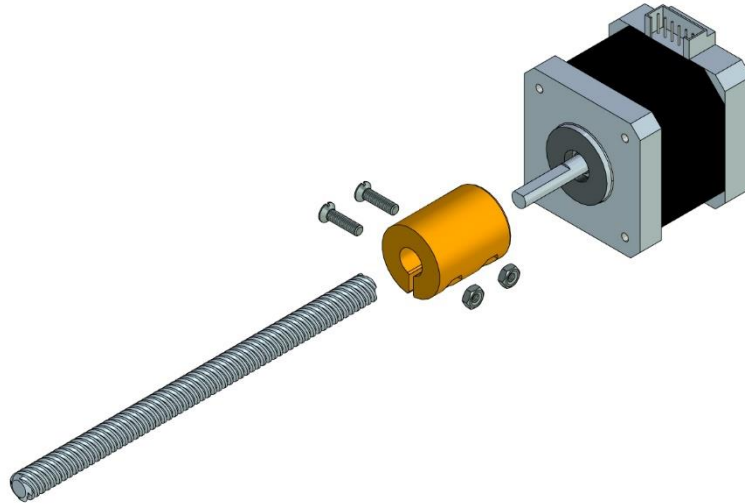

\* metal rigid coupling can be used instead of 3D printed part  
\*\* flexible beam coupling is not recommended to use

### Step 1.2 (assemble according to the drawing)

| PART # | PART NAME               | QTY |
|--------|-------------------------|-----|
| 17     | Back Support            | 1   |
| 27     | Nut M3                  | 2   |
| 30     | Countersunk Screw M3x20 | 4   |

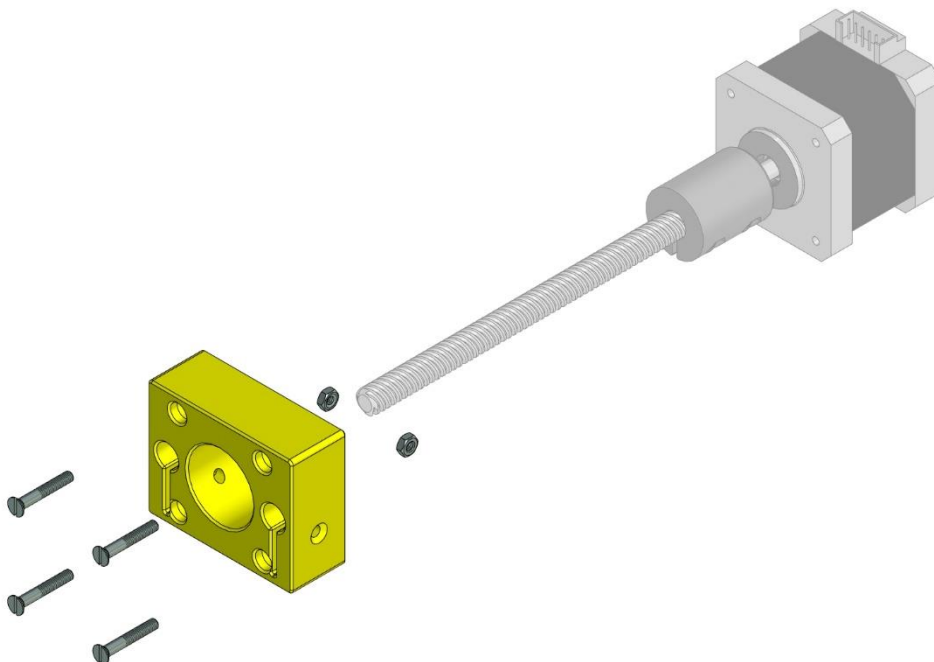

### Step 1.3 (assemble according to the drawing)

| PART # | PART NAME               | QTY |
|--------|-------------------------|-----|
| 5      | Guide Rod (D=8mm)       | 2   |
| 29     | Countersunk Screw M3x14 | 2   |

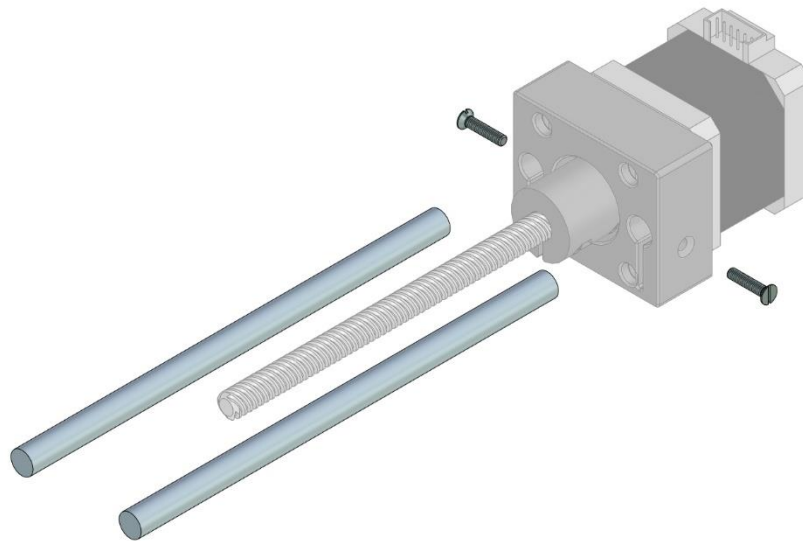

### Step 1.4 (assemble according to the drawing)

| PART # | PART NAME               | QTY |
|--------|-------------------------|-----|
| 10     | Carriage                | 1   |
| 11     | Endstop Switch          | 2   |
| 12     | Wire Holder             | 1   |
| 13     | Linear Bearing (LM8SUU) | 2   |
| 15     | Lead Screw Nut (T8)     | 1   |
| 27     | Nut M3                  | 6   |
| 28     | Countersunk Screw M3x12 | 2   |
| 31     | Pan Head Screw M3x16    | 4   |
| 35     | Self-tapping Screw 2x8  | 2   |
| 36     | Self-tapping Screw 2x10 | 4   |

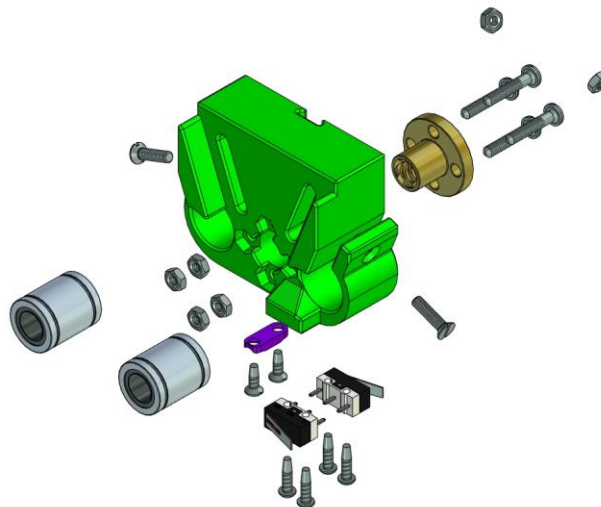

\* before installing the endstop switches solder the wires (refer to step 2.3)

**Step 1.5** (assemble according to the drawing)

| PART # | PART NAME       | QTY |
|--------|-----------------|-----|
| 2b     | Hand Knob (8mm) | 2   |
| 9      | Plunger Holders | 1   |
| 14     | Slider          | 1   |
| 27     | Nut M3          | 2   |
| 34     | Bolt M3x35      | 2   |

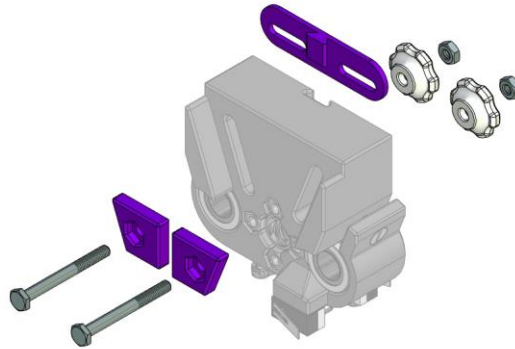

**Step 1.6** (assemble according to the drawing)

| PART # | PART NAME       | QTY |
|--------|-----------------|-----|
| 2c     | Hand Knob (7mm) | 2   |
| 6      | Limit Stop      | 2   |
| 27     | Nut M3          | 2   |
| 32     | Bolt M3x20      | 2   |

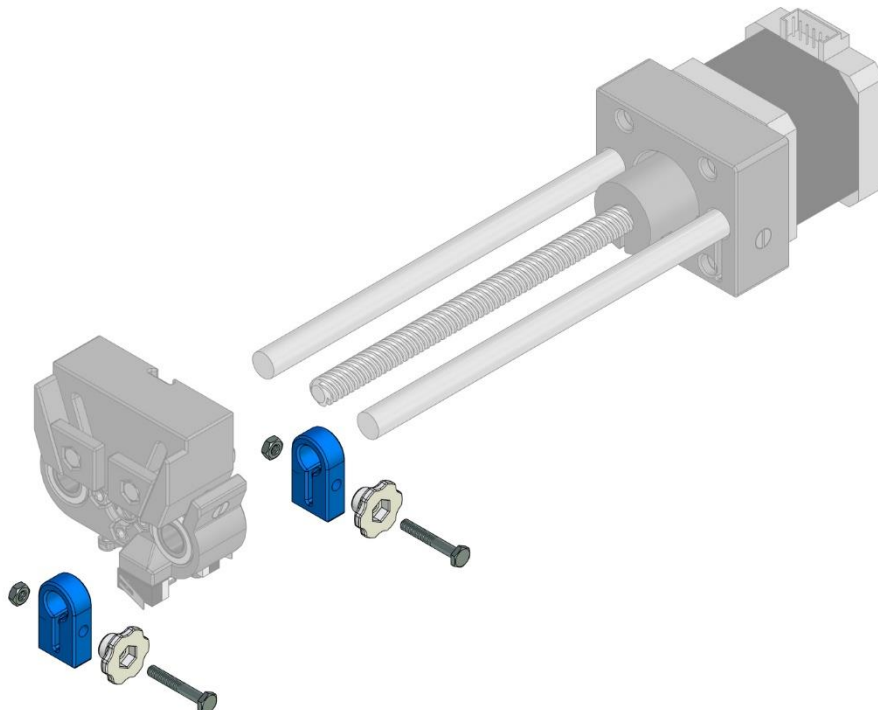



**Step 1.7** (assemble according to the drawing)

| PART # | PART NAME           | QTY |
|--------|---------------------|-----|
| 1      | Front Support       | 1   |
| 2a     | Hand Knob (9mm)     | 4   |
| 3      | Top Syringe Holder  | 1   |
| 4      | Side Syringe Holder | 1   |
| 27     | Nut M3              | 4   |
| 33     | Bolt M3x25          | 2   |
| 34     | Bolt M3x35          | 2   |

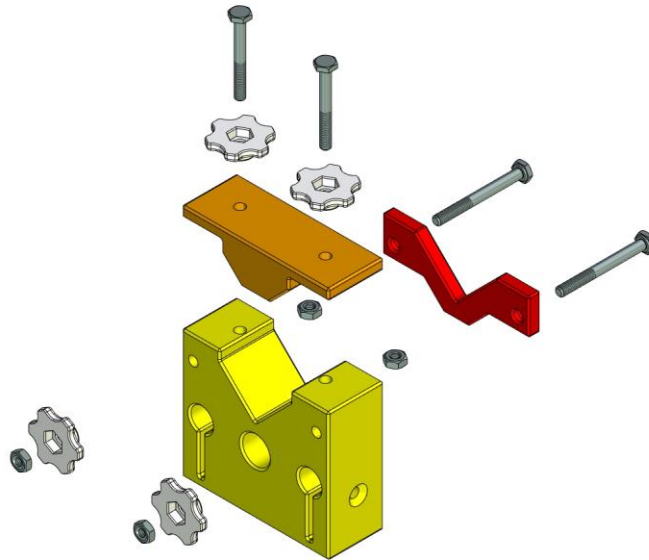

**Step 1.8** (assemble according to the drawing)

| PART # | PART NAME               | QTY |
|--------|-------------------------|-----|
| 7      | Bearing 688ZZ           | 1   |
| 27     | Nut M3                  | 2   |
| 29     | Countersunk Screw M3x14 | 2   |

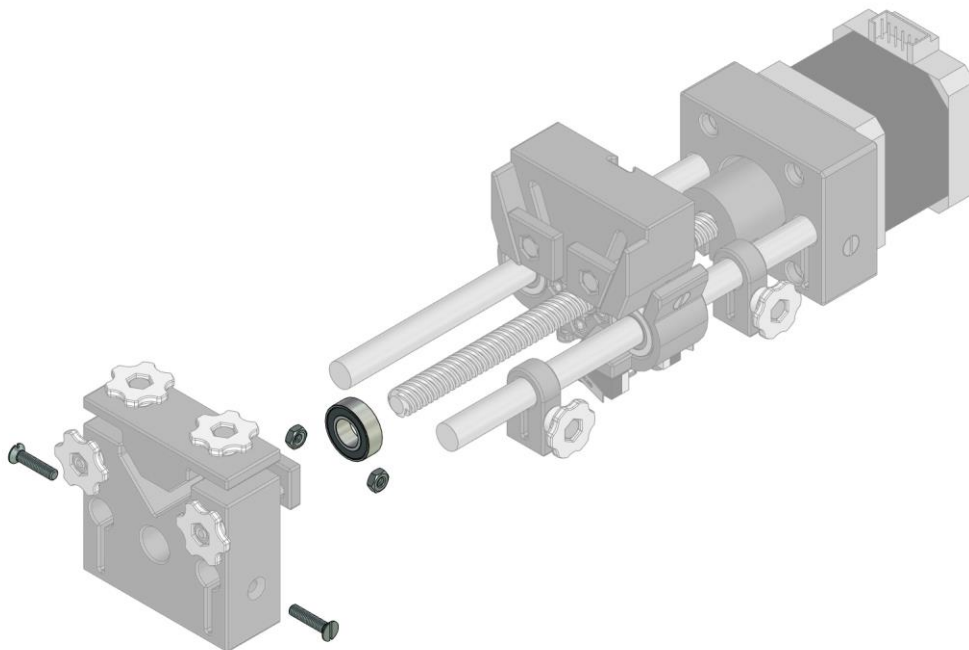

### Step 2.1 (if necessary, change the basic settings in the Arduino sketch)

```
/*
*****
      BASIC SETTINGS
*****
*/

// Stepper motor
#define NFMICROSTEPS 16      // The number of microsteps per step
#define NOFSTEPSPER360 200  // The number of steps per revolution
#define MAXRPM 240          // Maximum RPM (rotations per minute)
#define INVERTDIRECTION true // If the carriage moves in the opposite direction, change to 'false'

// Leadscrew
#define MMPER360 2          // Leadscrew pitch, mm per revolution

// Arduino pins
#define STEP_PIN 2          // STEP pin (A4988)
#define DIRECTION_PIN 3    // DIR pin (A4988)
#define ENABLE_PIN 12       // EN pin (A4988)
#define ENDSTOP_PIN1 A1     // Endstop pin (forward movement)
#define ENDSTOP_PIN2 A2    // Endstop pin (backward movement)
#define BUZZER_PIN 11       // Buzzer pin
#define BUTTONS_PIN A0      // Button pin (lcd keypad shield)

/*
*****
*/
```

### Step 2.2 (upload sketch to Arduino) Detailed instructions are available at [this link](#).

### Step 2.3 (solder wires and crimp connectors, refer to electrical circuit)

| PART # | PART NAME                 | QTY |
|--------|---------------------------|-----|
| 22     | Arduino UNO               | 1   |
| 26     | Active Buzzer (D=12mm)    | 1   |
| 37     | Dupont Connector (Female) | 6   |
| 38     | Dupont Connector (Male)   | 3   |
| 39     | Dupont Housing (3P)       | 2   |
| 40     | Connector Wires           | –   |

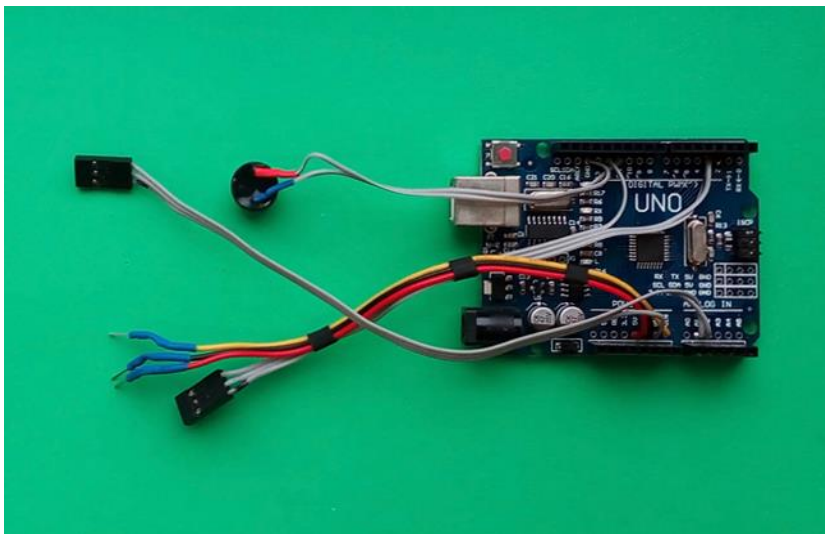

**Step 2.4** (solder wires and crimp connectors, refer to electrical circuit)

| PART # | PART NAME               | QTY |
|--------|-------------------------|-----|
| 11     | Endstop Switch          | 2   |
| 38     | Dupont Connector (Male) | 3   |
| 39     | Dupont Housing (3P)     | 1   |
| 40     | Connector Wires         | -   |



**Step 2.5** (plug A4988 driver into the shield and set all DIP switches to ON)

| PART # | PART NAME                    | QTY |
|--------|------------------------------|-----|
| 24     | Stepper Motor Driver (A4988) | 1   |
| 25     | Control Shield for A4988     | 1   |



**Step 2.6** (set output current limit on A4988)  
Detailed instructions are available at [this link](#).

**Step 2.7** (connect all electronic components together; connect stepper motor and endstop switches; plug in 12 V power supply; make sure that pump works)

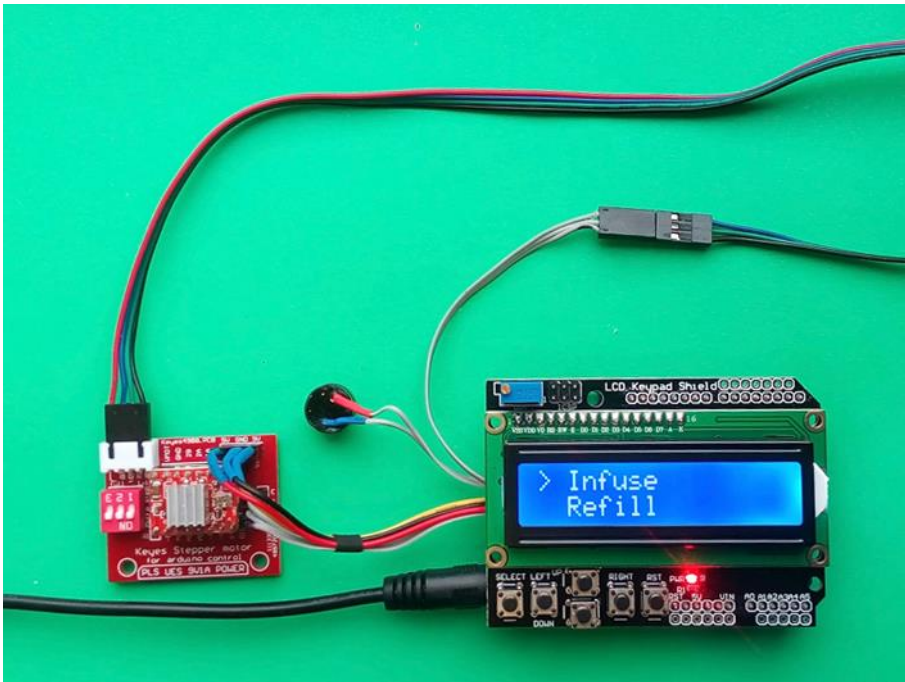

**Step 2.8** (place active buzzer, Dupont housing, and shield with A4988 into the case)

| PART # | PART NAME              | QTY |
|--------|------------------------|-----|
| 19     | Case (Base)            | 1   |
| 35     | Self-tapping Screw 2x8 | 2   |

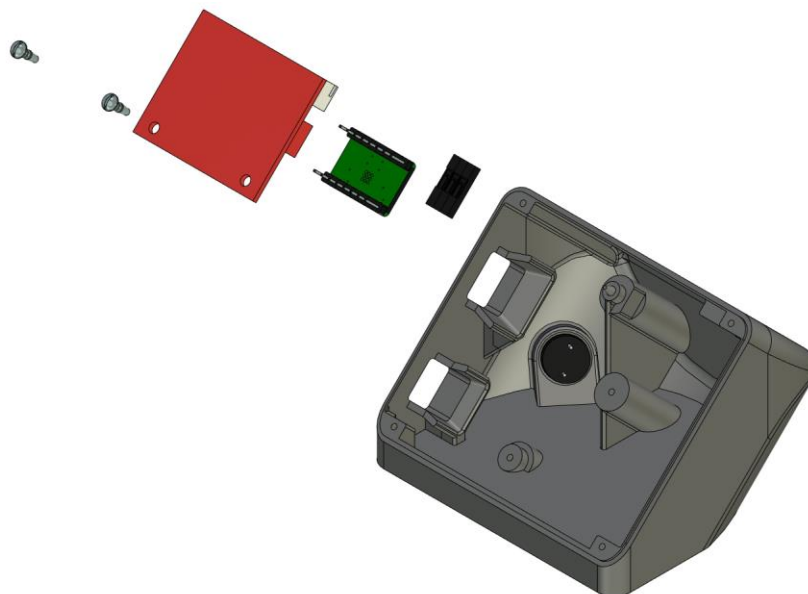

**Step 2.9** (place Arduino UNO into the case)

| PART # | PART NAME              | QTY |
|--------|------------------------|-----|
| 35     | Self-tapping Screw 2x8 | 2   |

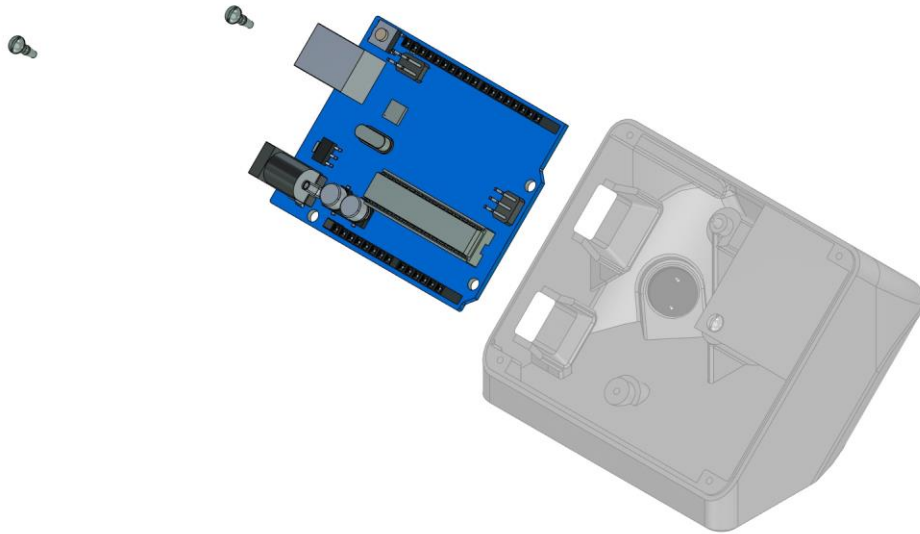

**Step 2.10** (plug LCD Keypad Shield into Arduino UNO)

| PART # | PART NAME         | QTY |
|--------|-------------------|-----|
| 23     | LCD Keypad Shield | 1   |

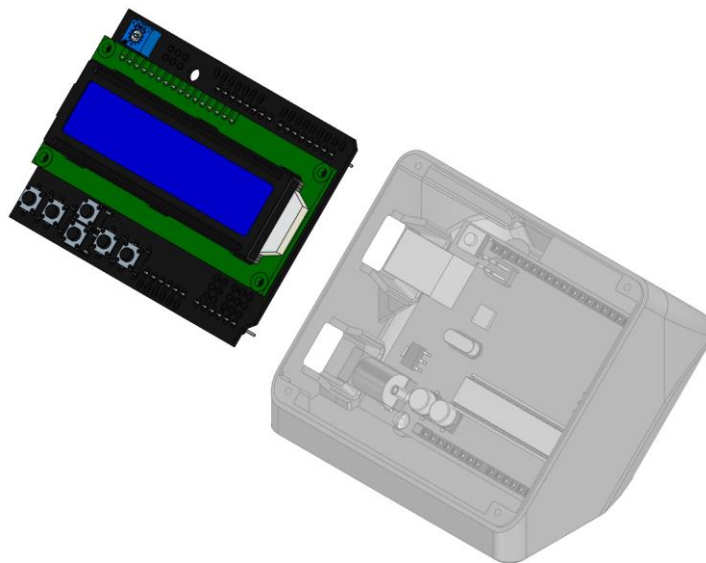

**Step 2.11** (install buttons and top cover)

| PART # | PART NAME               | QTY |
|--------|-------------------------|-----|
| 20     | Case (Cover)            | 1   |
| 21     | Buttons                 | 1   |
| 36     | Self-tapping Screw 2x10 | 4   |

